

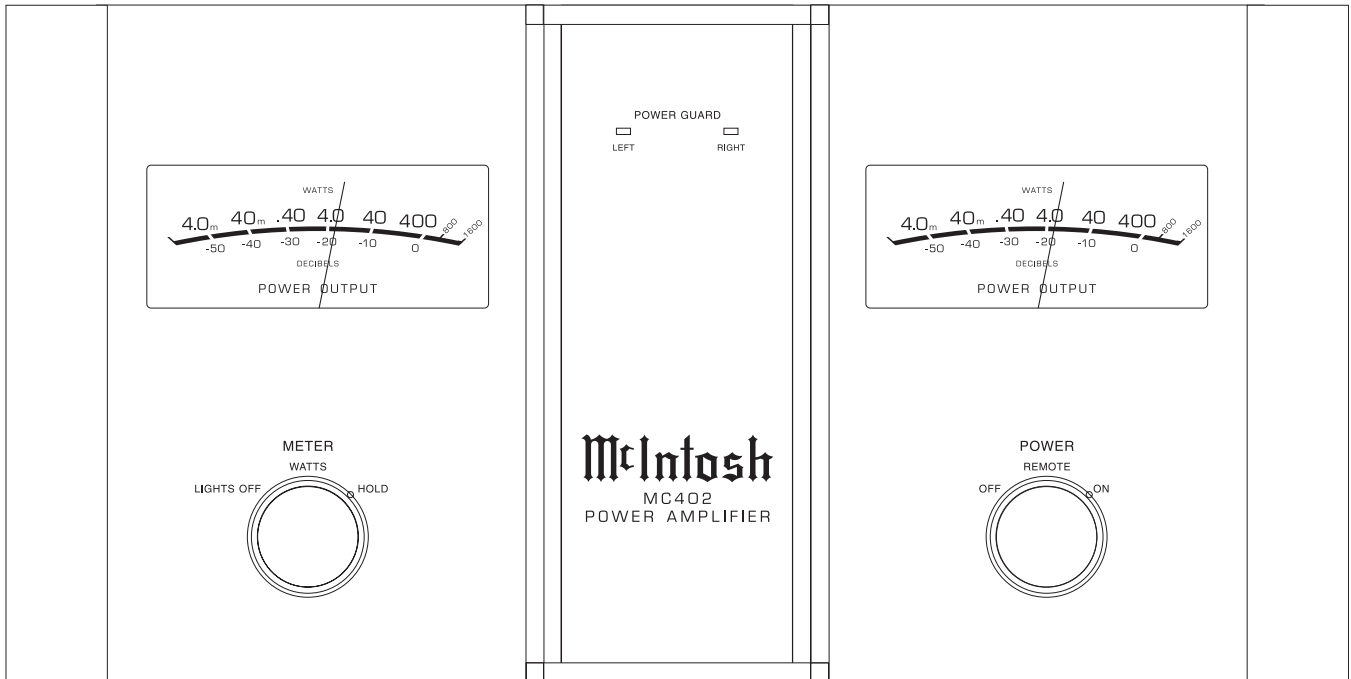

MC402

POWER AMPLIFIER



CONTENTS

Performance Specifications	2	Input Schematic and PCB	17 - 18
Notes	2	Capacitor Schematic and PCB	19 - 20
Rear Panel	3	Meter	21 - 25
Section Location	4	Indicator Schematic and PCB	26
Block Diagram	5 - 6	Meter LED Schematic and PCB	27 - 28
Interconnection Diagram	7 - 8	Parts List	27 - 30
Heatsink Schematic and PCB	9 - 12	Exploded View and Parts List	31 - 36
Driver Schematic and PCB	13 - 16	Repacking Instructions	37

SERVICE MANUAL

PERFORMANCE SPECIFICATIONS

Power Output Stereo

Minimum sine wave continuous average power output per channel, all channels operating is:

400 watts into 2 ohm load
400 watts into 4 ohm load
400 watts into 8 ohm load

Power Output Mono Parallel

Minimum sine wave continuous average power output is:

800 watts into 1 ohm load
800 watts into 2 ohm load
800 watts into 4 ohm load

Output Load Impedance

2, 4 or 8 ohms (Stereo Mode)
1, 2 or 4 ohms (Mono Mode)

Rated Power Band

20Hz to 20,000Hz

Total Harmonic Distortion

Maximum Total Harmonic Distortion at any power level from 250 milliwatts to rated power output is 0.005%

Intermodulation Distortion

Maximum Intermodulation Distortion if instantaneous peak output per channel does not exceed twice the rated output, for any combination of frequencies from 20Hz to 20,000Hz, with all channels operating is 0.005%

Dynamic Headroom

2.1dB

Frequency Response

+0, -0.25dB from 20Hz to 20,000Hz
+0, -3dB from 10Hz to 100,000Hz

Sensitivity

2.0 Volts Unbalanced Input
4.0 Volts Balanced Input

A-Weighted Signal To Noise Ratio

94dB Unbalanced (120dB below rated output)
98dB Balanced (124dB below rated output)

Input Impedance

10,000 ohms Unbalanced Inputs
20,000 ohms Balanced Inputs

Wide Band Damping Factor

Greater than 40

Power Requirements

100 Volts, 50/60Hz at 12 amps
110 Volts, 50/60Hz at 11 amps
120 Volts, 50/60Hz at 10 amps
220 Volts, 50/60Hz at 5 amps
230 Volts, 50/60Hz at 5 amps
240 Volts, 50/60Hz at 5 amps

Note: Refer to the rear panel of the MC402 for the correct voltage.

Overall Dimensions

17-1/2 inches (44.45cm) W, 9-7/16 inches (23.97cm) H, 20 inches (50.8cm) D, including clearance for connectors

Weight

110.5 pounds (50.1kg) net, 143.5 pounds (65.1kg) in shipping carton

NOTES

1. The heavy notes on the schematic denote the primary signal path.
2. Unless otherwise noted, all voltages indicated on the schematics are measured under the following conditions:
 - a. AC input at 120 volts, 50/60Hz.
 - b. All voltages are +/-10% with respect to ground. A high impedance (10 megaohm) voltmeter must be used.
3. Unless otherwise specified:
 - a. Resistor values are in ohms.
 - b. Capacitor values are microfarads (uF).
 - c. Inductor values are in microhenries (uH).
4. On PC board drawings, Square pad indicates:
 - a. Polarized Capacitors - Positive
 - b. Diodes - Cathode
 - c. Others - Pin 1
5. **WARNING**
Parts marked with the symbol  have critical characteristics. Use only replacement parts recommended by the manufacturer.

REAR PANEL

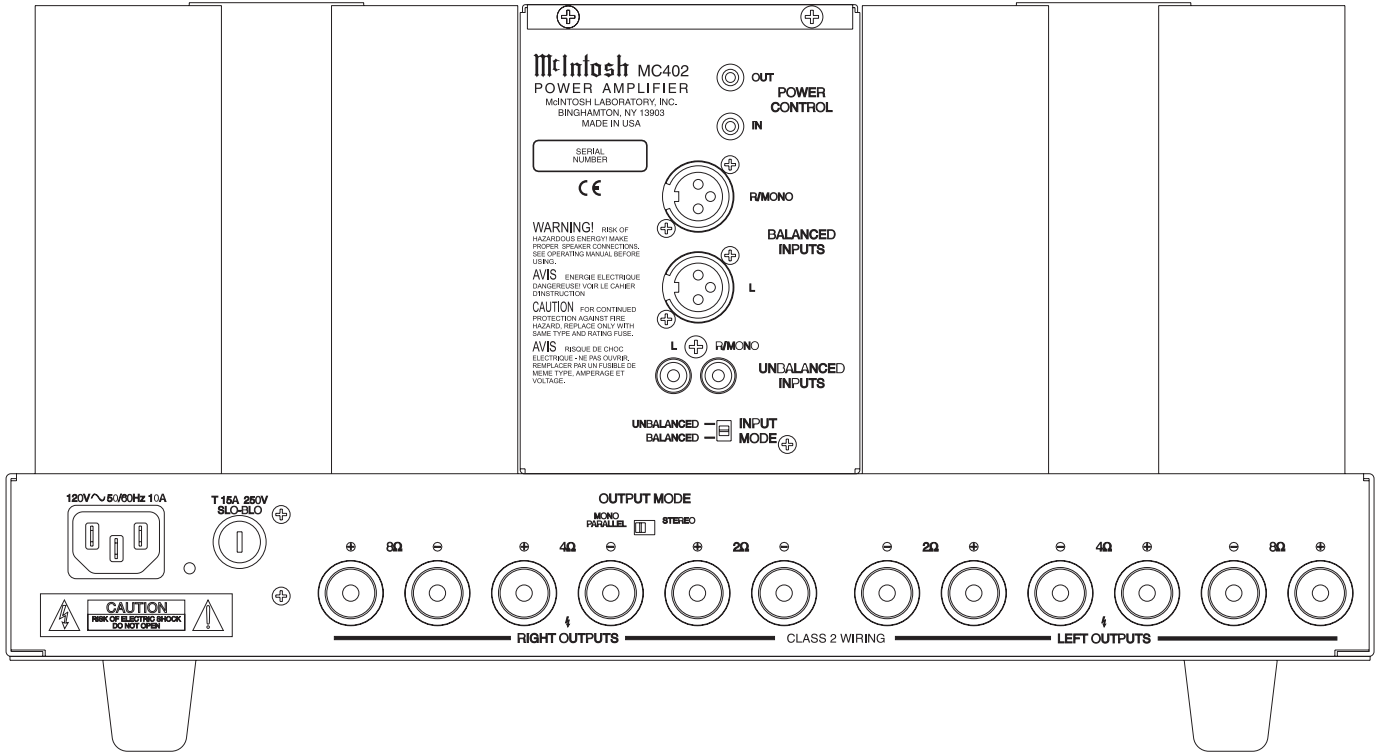

SECTION LOCATIONS

TOP VIEW WITH COVER REMOVED

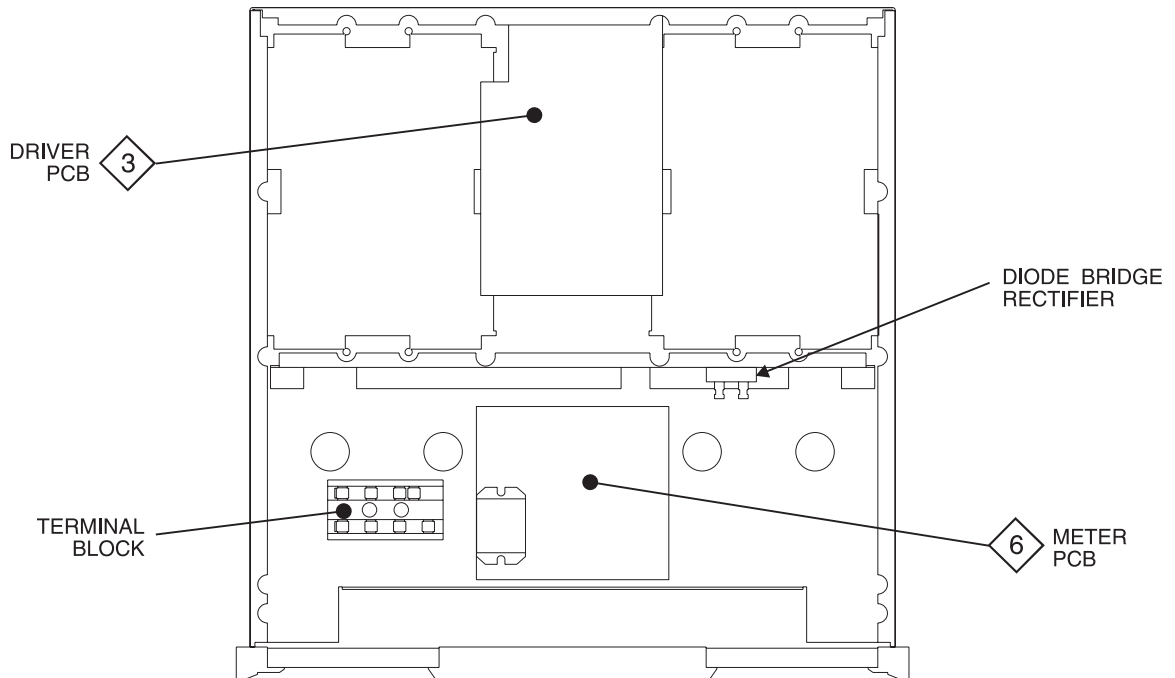
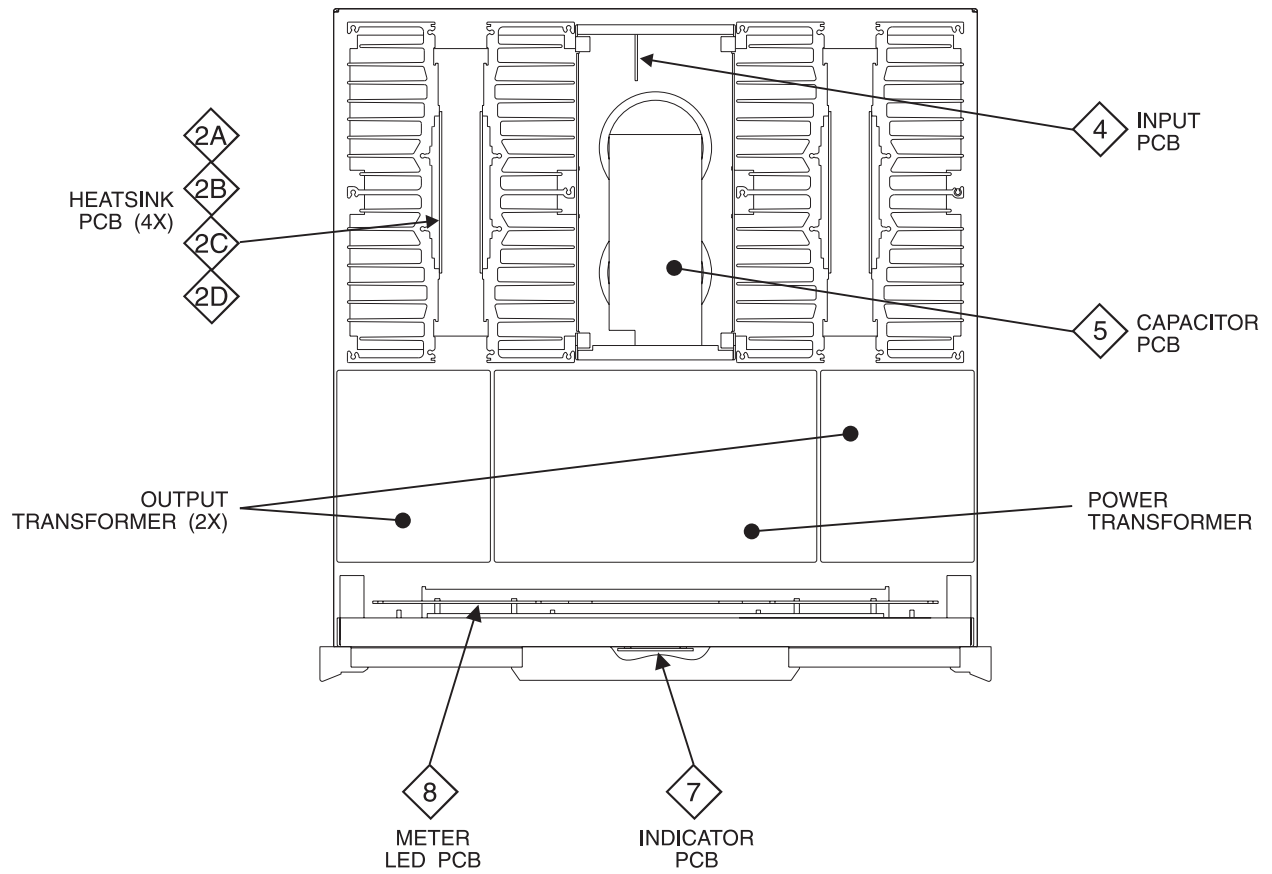

BOTTOM VIEW WITH COVER REMOVED

BLOCK DIAGRAM

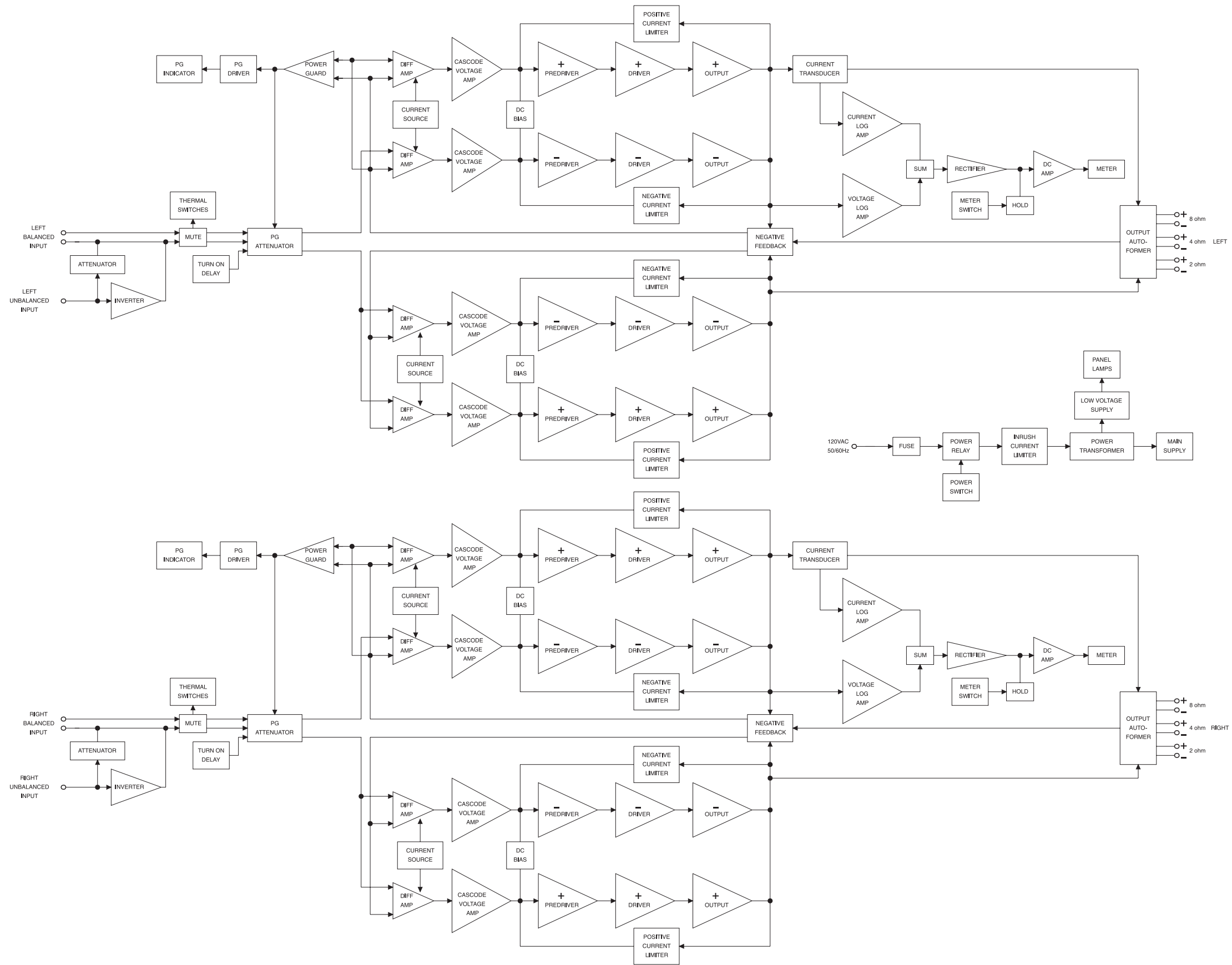

1 INTERCONNECT

! WARNING Parts located in the shaded area have critical characteristics. Use only replacement parts recommended by the manufacturer.

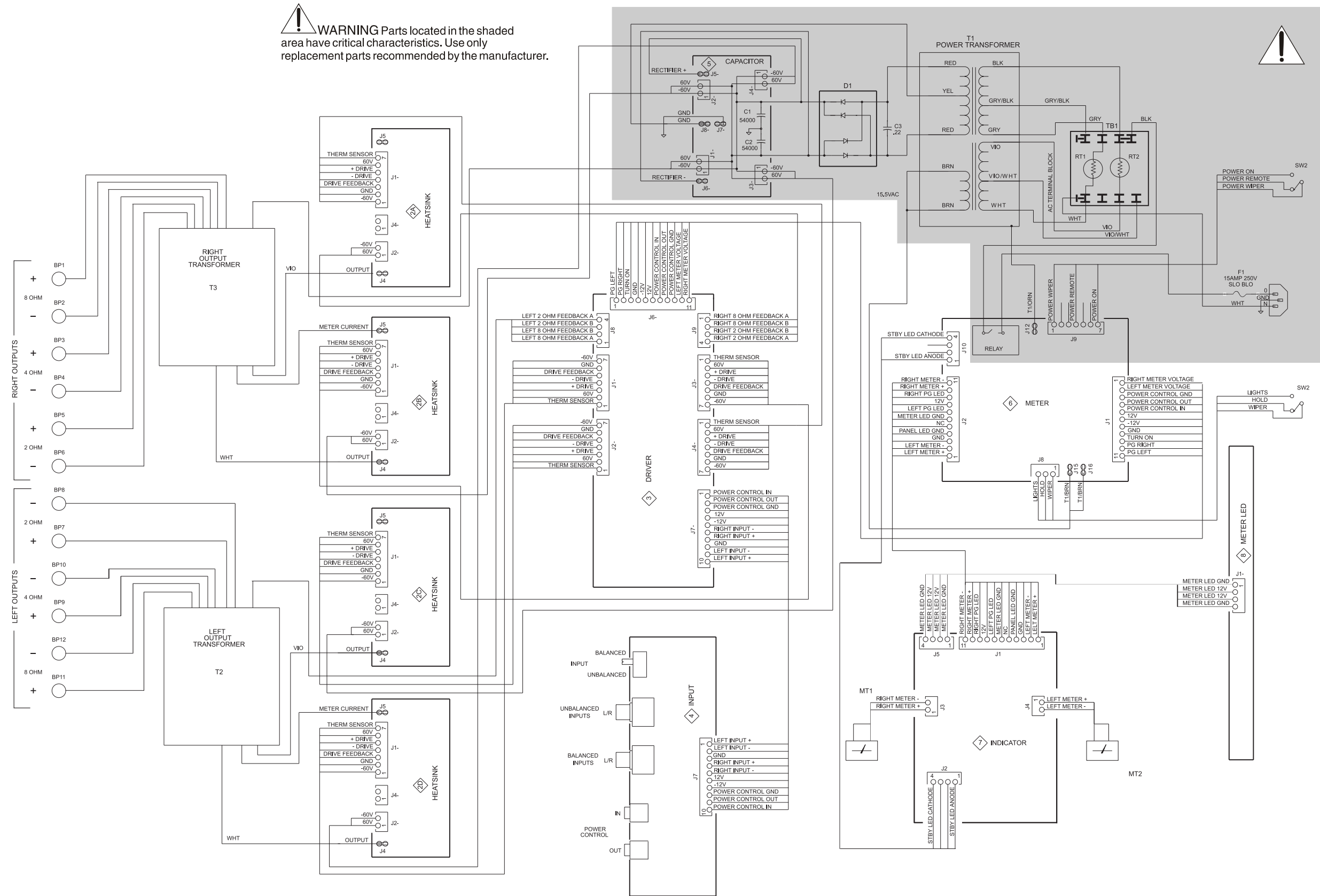

2A 2B 2C 2D

HEATSINK 049826

MC402

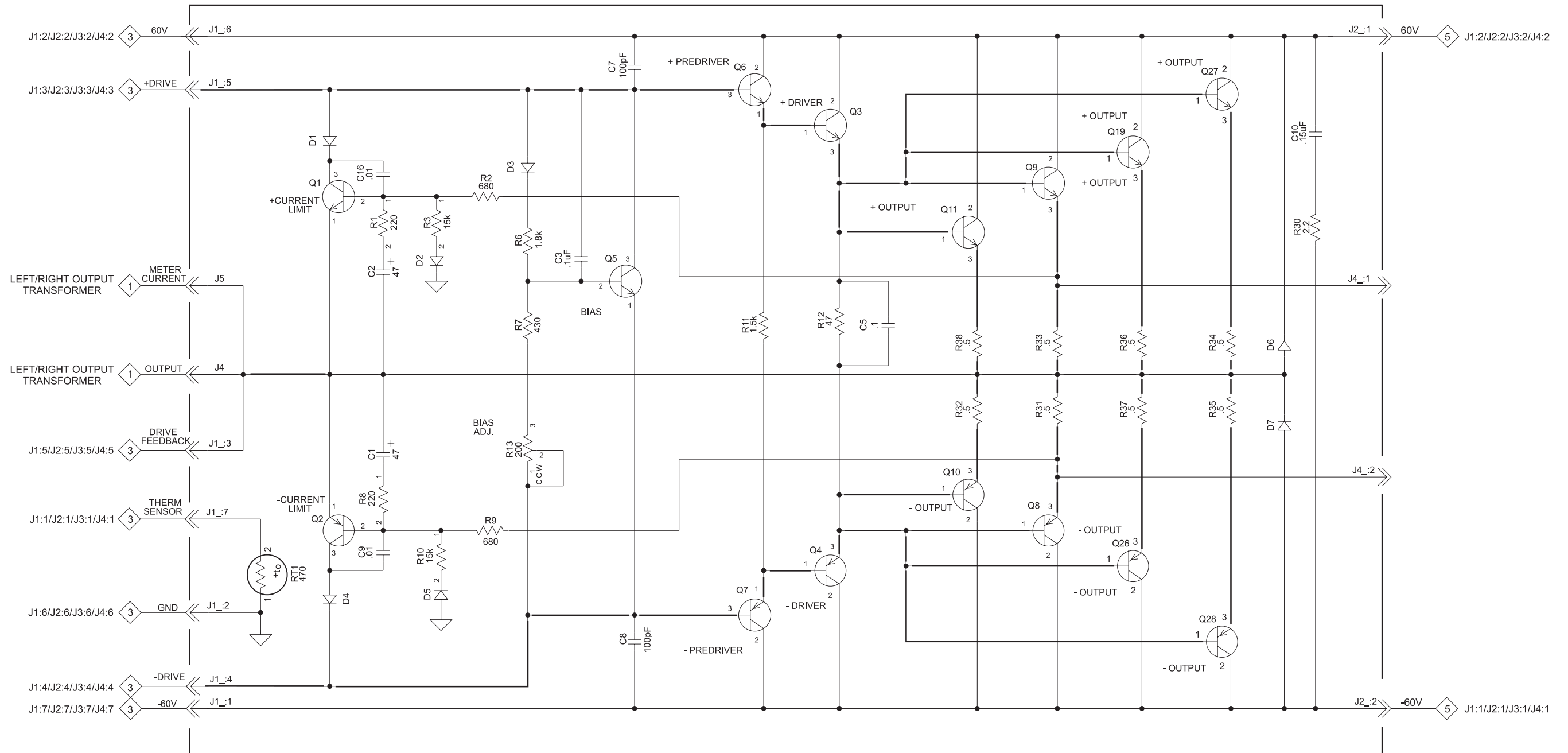

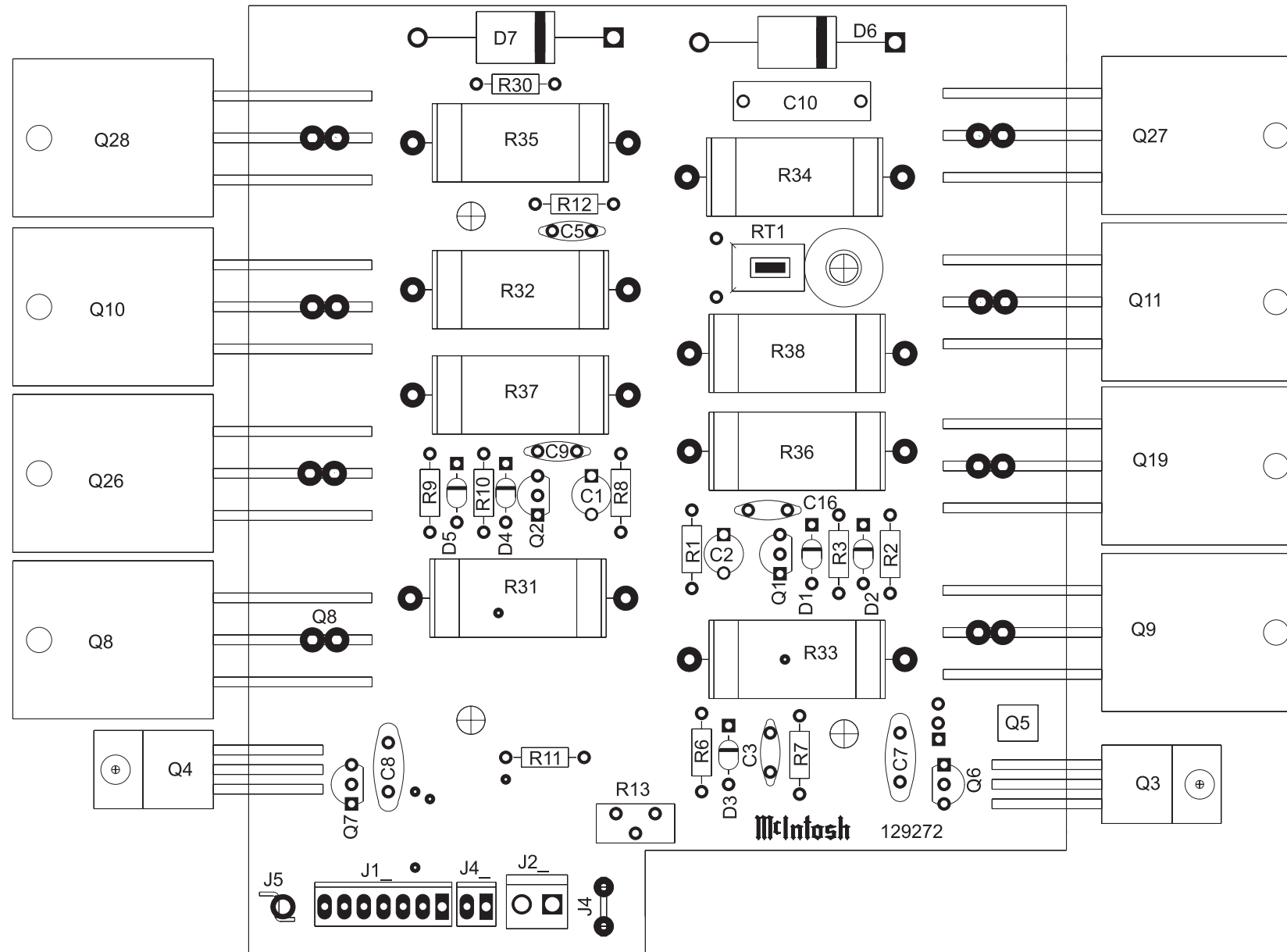

3 DRIVER 049219

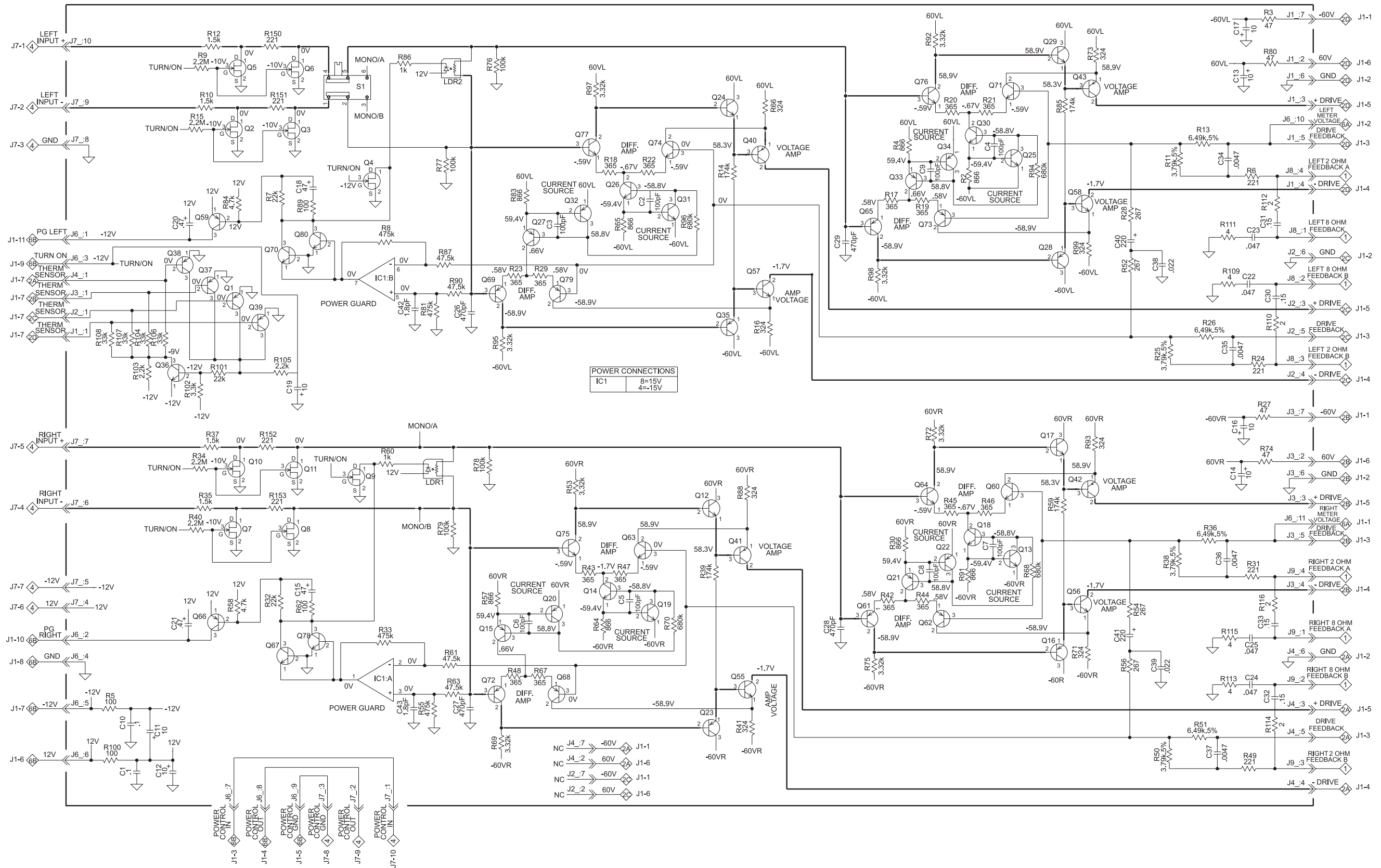

3 DRIVER 049219

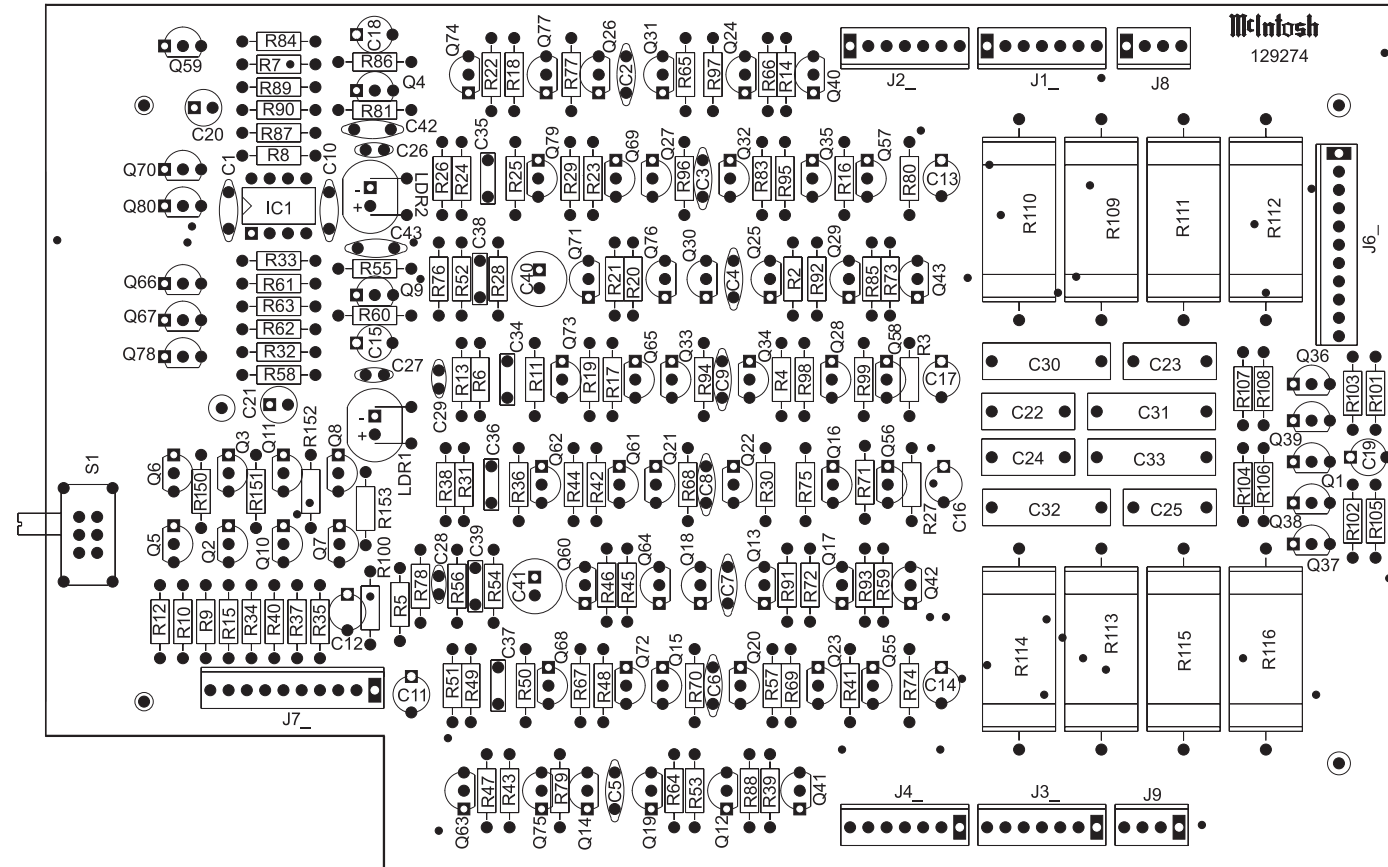

4 INPUT 049222

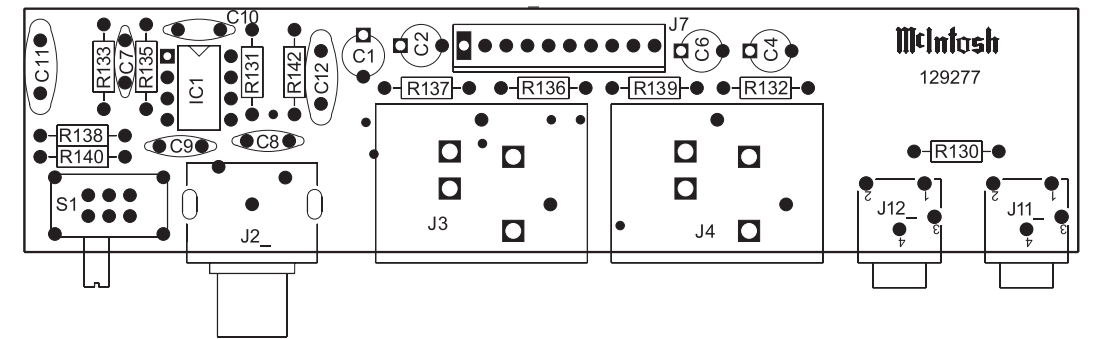
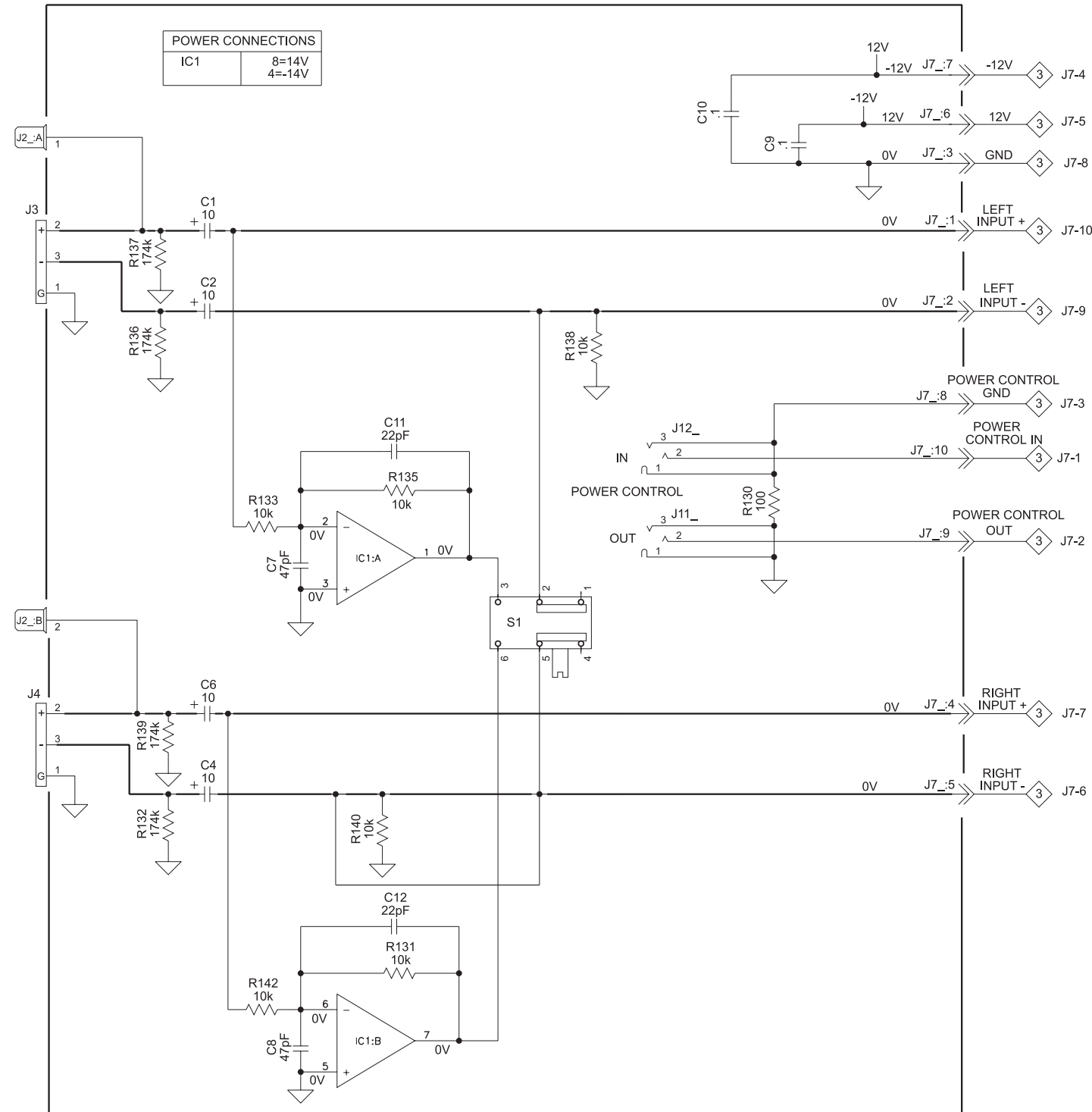

5 CAPACITOR 049216

! WARNING Parts located in the shaded area have critical characteristics. Use only replacement parts recommended by the manufacturer.

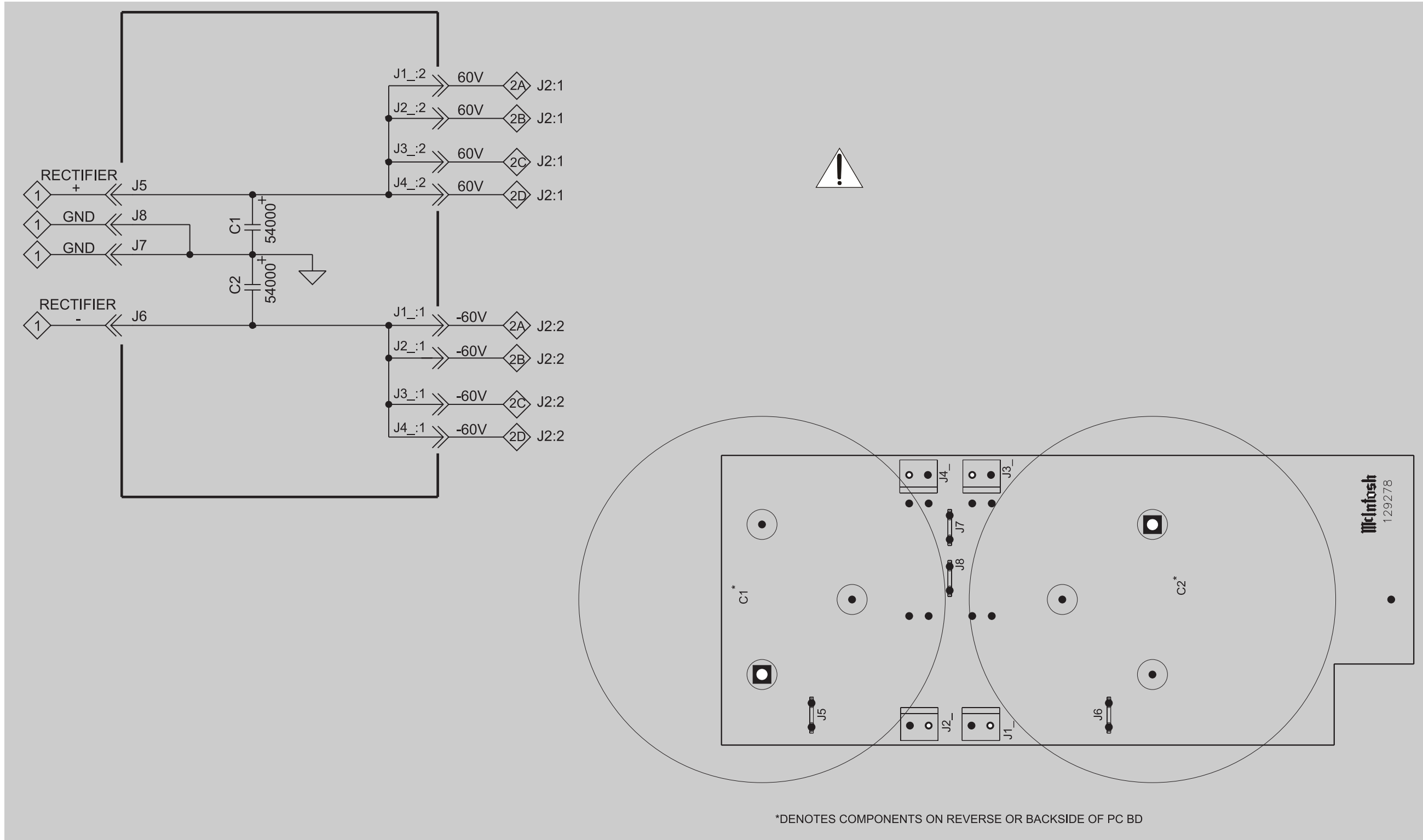

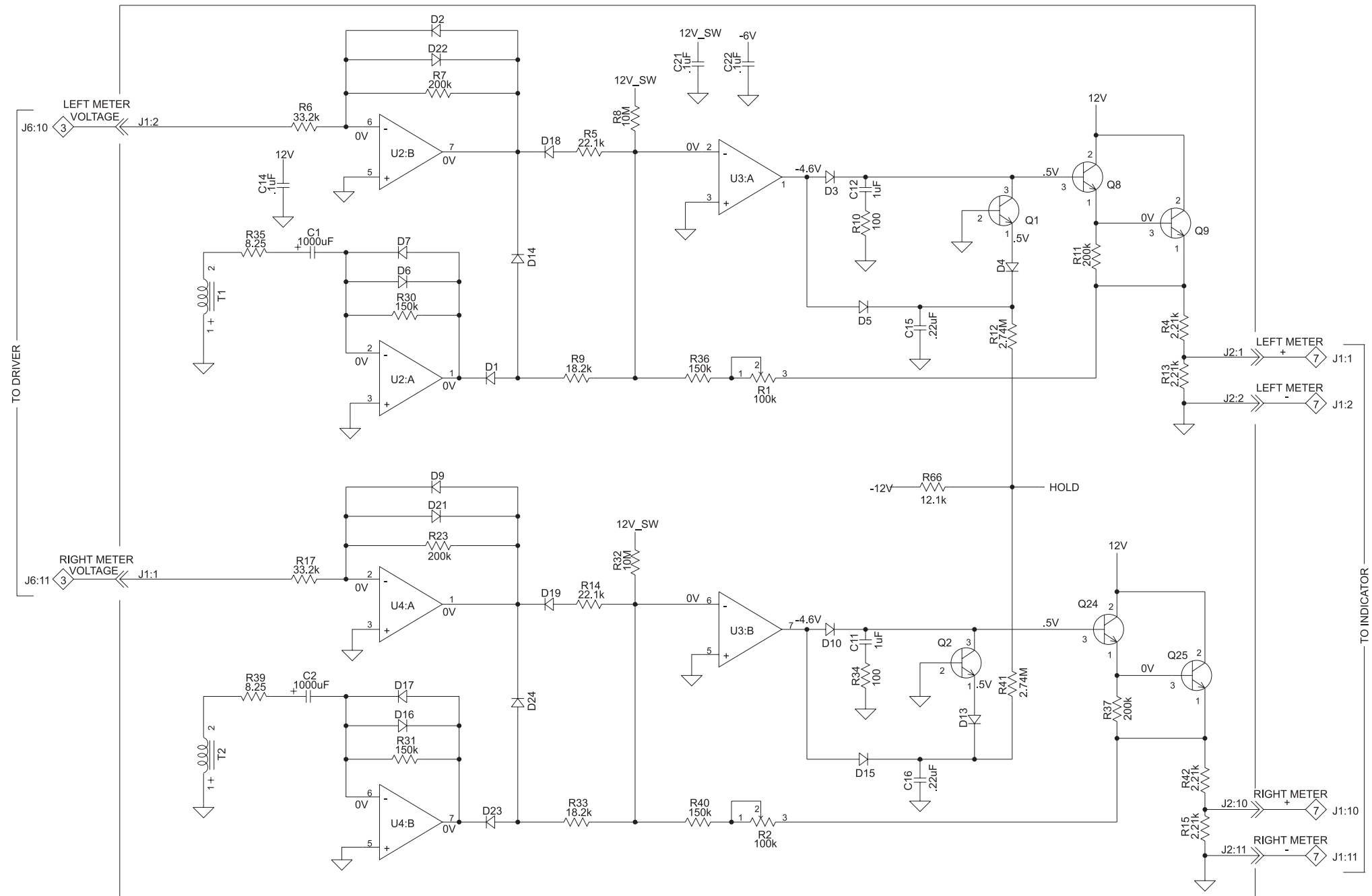

! WARNING Parts located in the shaded area have critical characteristics. Use only replacement parts recommended by the manufacturer.

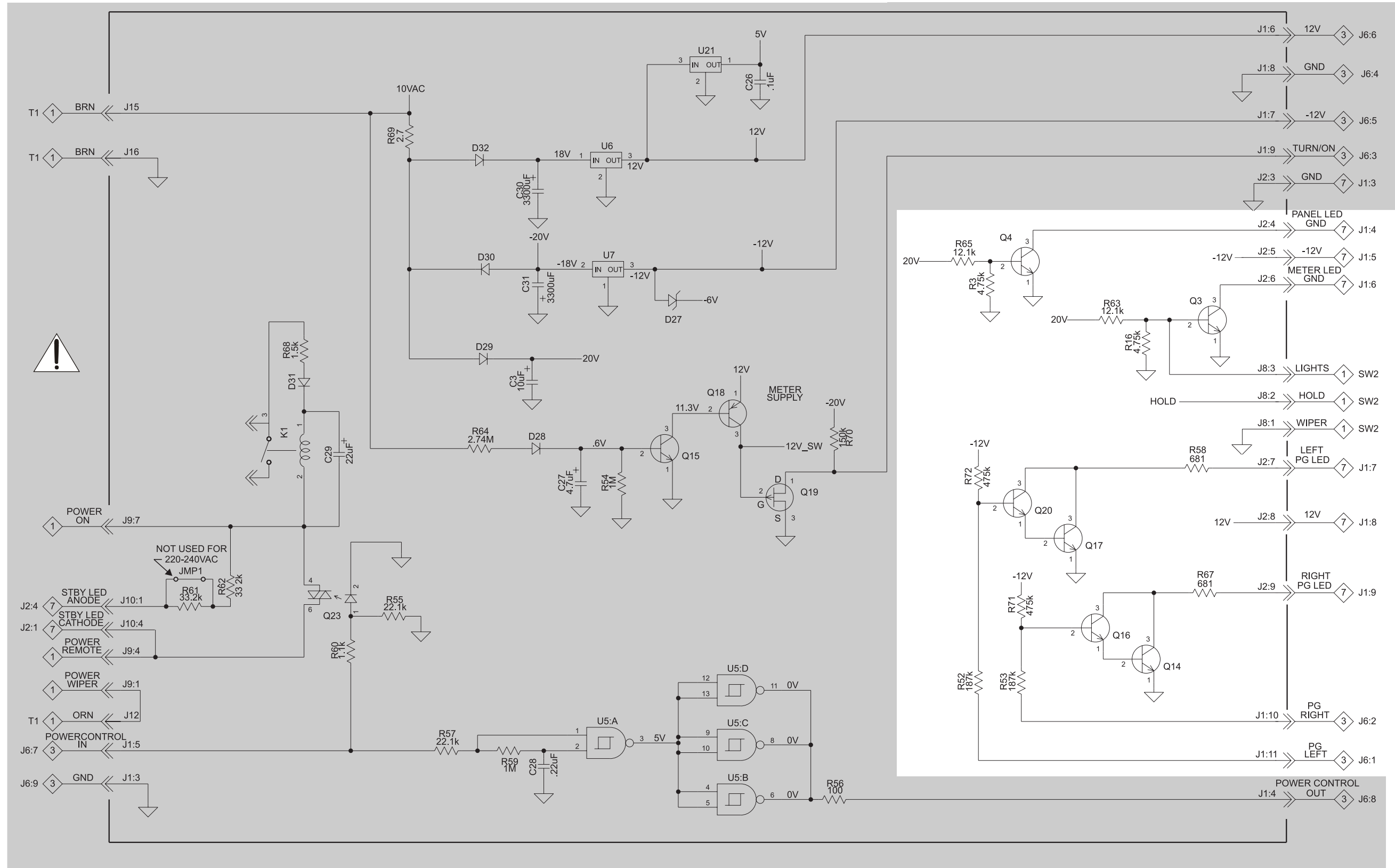

6 METER 049798

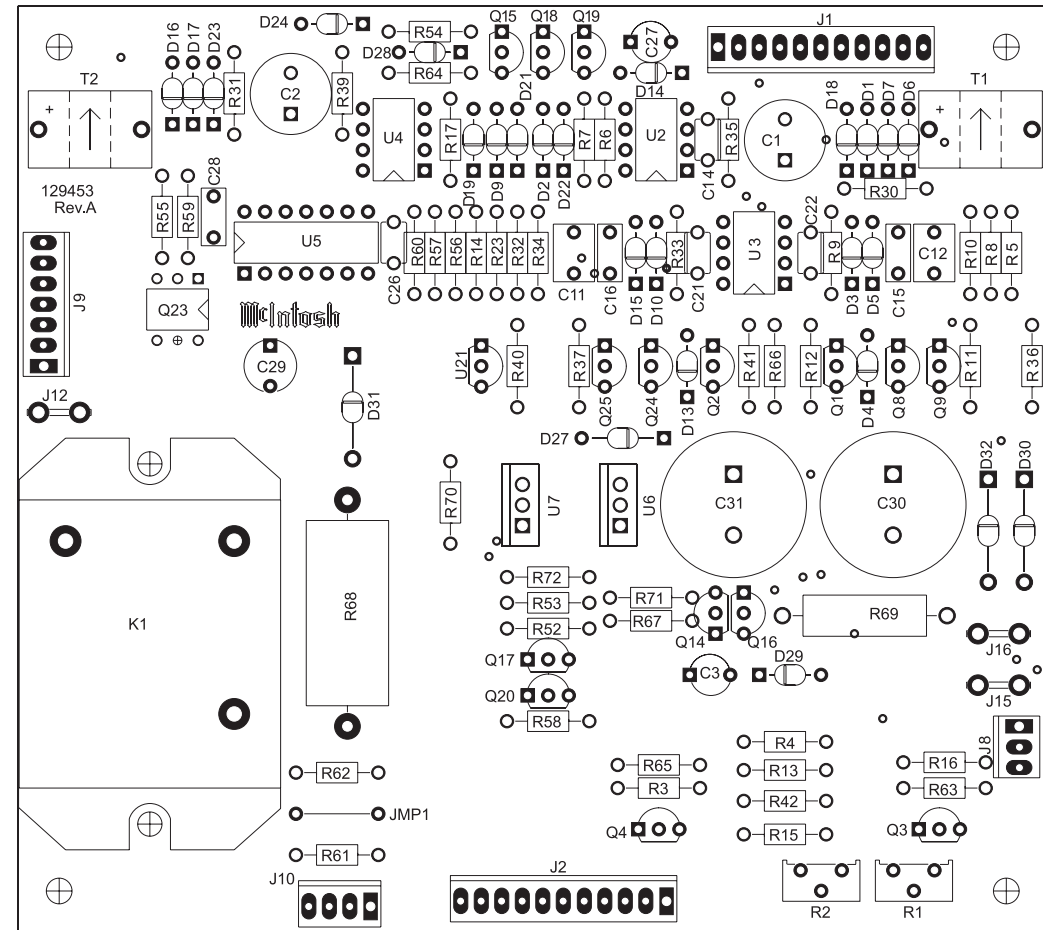

7 INDICATOR 049799

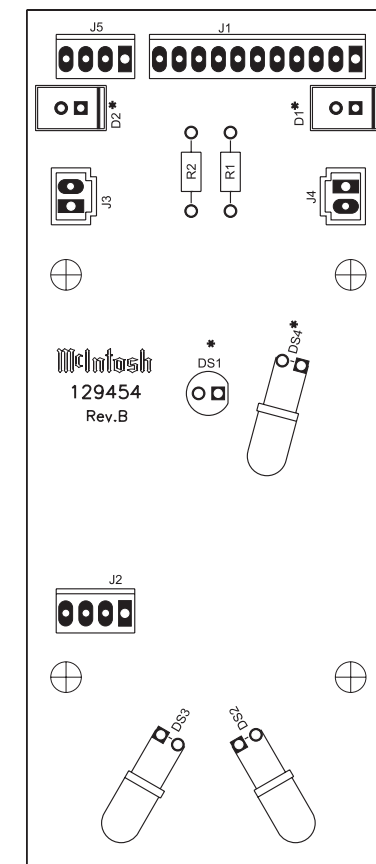
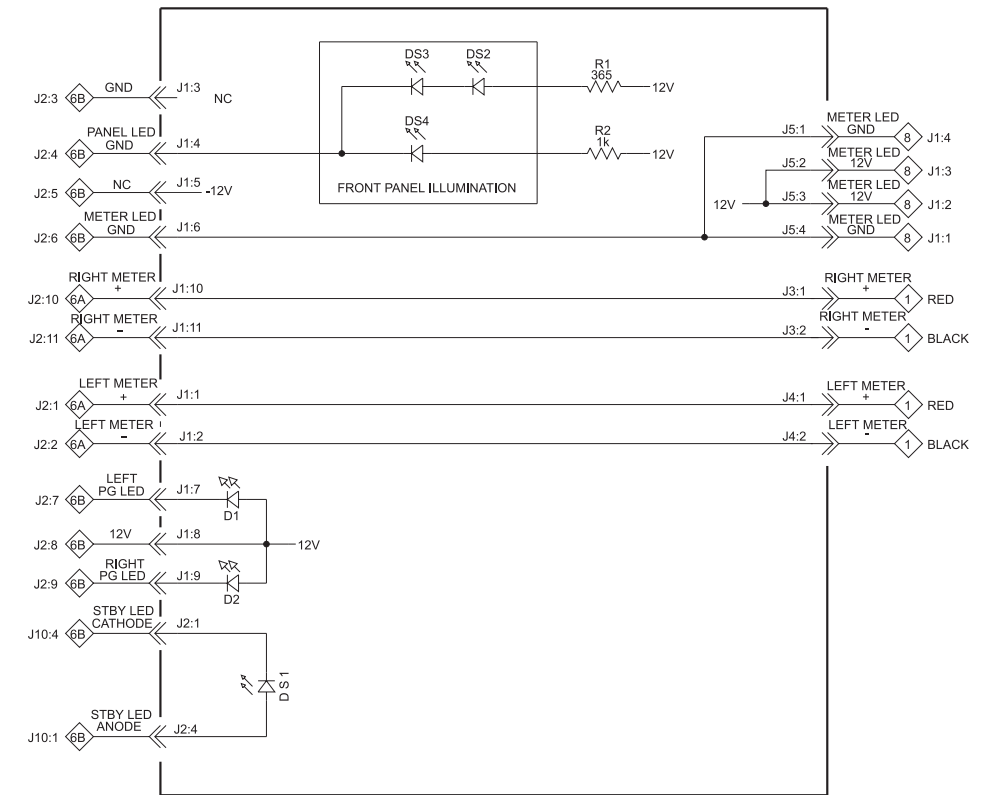



METER LED 049809

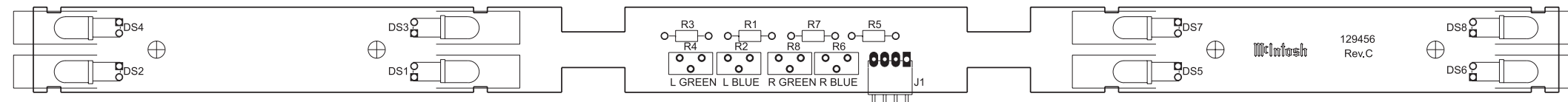
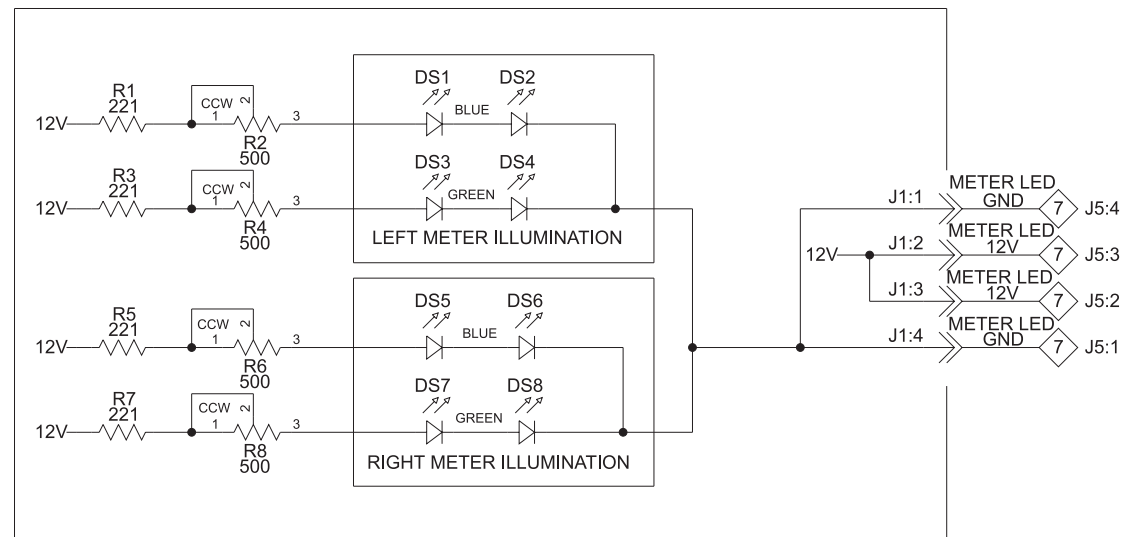

PARTS LIST

Ref. No.	Description	Part No.		
1	INTERCONNECT			
BP1 BP3 BP5 BP7 BP9 BP11	5 WAY BINDING POST (RED)	117740	R1 R8	RES CF 220 OHM 5% 1/4W
BP2 BP4 BP5 BP8 BP10 BP12	5 WAY BINDING POST (BLACK)	117741	R2 R9	RES MET OX 680 OHM 5% .5W
C1 C2	54000uF 75VDC	066480	R3 R10	RES CF 15K 5% 1/4W
C3	.22uF CAPACITOR	052005	R6 R11	RES MET OX 1.8K 5% .5W
D1	BRIDGE RECTIFIER	070139	R7	RES MET OX 430 OHM 5% .5W
F1	15 AMP 250V SLO BLO	089042	R12	RES MET OX 47 OHM 5% .5W
RT1 RT2	THERMISTER	052008	R13	POT TRIM 200 OHM 20% HORIZ AD
SW1 SW2	POWER/METER SWITCH	146243	R30	RES CF 2.2 OHM 5% 1/4W
T1	POWER TRANSFORMER	049818	R31 R32 R33 R34 R35 R36 R37 R38	RES WW .5 OHM 5W 5%
T2 T3	OUTPUT TRANSFORMER	049817	RT1	SENSOR THERMAL
TB1	AC TERMINAL BLOCK	074091		
2A 2B 2C 2D	049826 HEATSINK		3	049219 DRIVER
C1 C2	CAP ELECT 47UF 35V	06644600	C1 C10	DISC CAP: .1MF, 25V, Y5T
C3 C5	CAP DISC .1UF 25V Y5T	06124800	C2 C3 C4 C5 C6 C7 C8 C9	DISC CAP 100PF 10% N1500 50V
C7 C8	CAP DISC 100PF 10% N1500	06102300	C11 C12 C13 C14 C16 C17 C19	ELECT CAP: 10 UF 100VDC AMMO
C9 C16	CAP CER 0.01UF 20% 50V	06115900	C15 C18	ELECT CAP 47MF, 35V AMMO PACK
C10	CAP POLYPROP 0.15UF 10% 250VDC	06436300	C20 C21	CAP ELECT 0.47UF 50V ALUM
D1 D2 D3 D4 D5	DIODE SILICON	07004700	C22 C23 C24 C25	POLYPROPY CAP.047MF 250V
D6 D7	DIODE 200V 6A	07013300	C26 C27 C28 C29	M.CAP: 470PF, 5%, 100V
J1-	CONN MALE 7 PIN	11721700	C30 C31 C32 C33	POLYPROPY CAP 0.15MF 250V
J2-	CONN HEADER 2 PIN 0.156	11740400	C34 C35 C36 C37	CAP MPOLY .0047UF 5% 63-250VDC
J4	BLADE FASTON W/FEET	11770800	C38 C39	CAP M POLY .022UF 5% 100VDC
J4-	CONN 2 PIN MALE	11721300	C40 C41	CAP ELECT 220UF 16V SHORT CAN
J5	BLADE FASTON .110	11771200	C42 C43	DISC CAP: 1.8PF .25PF NPO
Q1	TRANSISTOR NPN SILICON	13217100	IC1	DUAL OP AMP 4558
Q2	TRANSISTOR PNP SILICON	13217200	J1- J2- J3- J4-	MALE CONN: 7 PIN
Q3 Q6	TRANSISTOR NPN 25C3334C	13228500	J6-	11-POS. MALE CONN.
Q4 Q7	TRANSISTOR PNP 2SA32IC	13228600	J7-	MALE CONN: 10 POS
Q8 Q10 Q26 Q28	TRANSISTOR PNP POWER 2SA1943	13229200	J8 J9	4-PIN CONNECTOR
Q9 Q11 Q19 Q27	TRANSISTOR NPN POWER 2SC5200	13229100	LDR1 LDR2	RESISTOR LDR VTL5C9

PARTS LIST con't

Q31 Q36 Q67 Q70 Q78 Q80	TRANSISTOR NPN MPS4124	13222300
Q34 Q35 Q37 Q38 Q39 Q59 Q66	TRANSISTOR PNP SI MPS4126	13222400
Q40 Q41 Q42 Q43	TRANSISTOR PNP	13226100
Q55 Q56 Q57 Q58	TRANSISTOR NPN	13226200
Q68 Q69 Q72 Q73 Q79	TRANSISTOR PNP 2SA1016K	13225500
Q71 Q74 Q75 Q76 Q77	TRANSISTOR NPN	13225400
R2 R4 R30 R57 R64 R65 R83 R91	RES MF 866 1% 1/4W	14402800
R3 R27 R74 R80	FLAMEPROOF RES 47 OHM 5% 1/4W	13704200
R5 R62 R89 R100	RES CF 100 5% 1/4W	14102500
R6 R24 R31 R49 R150 R151 R152 R153	RES MF 221 OHMS 1% 1/4W	14417200
R7 R32 R101	RES CF 22K 5% 1/4W	14108000
R8 R33 R55 R81	RES MF 475K 1% 1/4W	14436400
R9 R15 R34 R40	RES CF 2.2M 5% 1/4W	14112400
R10 R12 R35 R37	RES MF 1.5K 1% 1/4W	14412800
R11 R25 R38 R50	RES MF 3.79K 0.5%	14439800
R13 R26 R36 R51	RES MF 6.49K .5% 1/4W	14440100
R14 R39 R59 R85	RES MF 174K 1% 1/4W	14435200
R16 R41 R66 R71 R73 R88 R93	RES MF 324 OHM 1% 1/4W	14433800
R17 R18 R19 R20 R21 R22 R23 R29	RES MF 365 1% 1/4W	14407100
R28 R52 R54 R56	RES MF 267 OHM 1% 1/4W	14417300
R42 R43 R44 R45 R46 R47 R48 R67	RES MF 365 1% 1/4W	14407100
R53 R69 R72 R75 R92 R95 R97	RES MF 3.32K 1% 1/4W	14409500
R58 R84	RES CF 4.7K 5% 1/4W	14106400
R60 R86	RES CF 1.0K 5% 1/4W	14104900
R61 R63 R87 R90	RES MF 47.5K 1% 1/4W	14410800
R68 R70 R94 R96	RES CF 680K 5% 1/4W	14111600
R76 R77 R78 R79	RES MF 100K 1% 1/4W	14411300
R98	RES MF 3.32K 1% 1/4W	14409500
R99	RES MF 324 OHM 1% 1/4W	14433800
R103 R105	RES CF 2.2K 5% 1/4W	14105700
R104 R106 R107 R108	RES CF 33K 5% 1/4W	14108400
R109 R111 R113 R115	WIRE RES: 4 OHMS 5% 5W	13911900
R110 R112 R114 R116	WIRE RES: 2 OHMS 10% 5W	13900500
S1	SLIDE SWITCH	14805900
4 049222 INPUT		
C1 C2 C4 C6	ELECT CAP 10MF, 50V AMMO PACK	06644500
C7 C8	DISC CAP: 47PF, 20%, N470 50V	06119600
C9 C10	DISC CAP: .1MF, 25V, Y5T	06124800
C11 C12	DISC CAP: 22PF, 10%, NPO 50V	06119100
IC1	DUAL OPERATIONAL AMPLIFIER	13326000
J2-	PJ261G PHON JACK, GOLD	11743600
J2 J3 J4 J11 J12	1/2 X 1" DOUBLE-SIDED TAPE	09419200
J2 J3 J4 J11 J12	ADHESIVE HOT MELT	09824900
J3 J4	XLR RECEPTACLE FEMALE	11768500
J7-	MALE CONN: 10 POS	11721900
J11- J12-	MINI JACK	11749400
R130	RES CF 100 5% 1/4W	14102500
R131 R133 R135 R138 R140 R142	RES MF 10K 1% 1/4W	14405300
R132 R136 R137 R139	RES MF 174K 1% 1/4W	14435200
S1	SLIDE SWITCH	14805900
5 049216 CAPACITOR		
J1- J2- J3- J4-	HEADER 2-PIN 0.156	11740400
J5 J6 J7 J8	FASTON BLADE W/FEET	11770800
6 049798 METER		
C1 C2	CAP ELECT 1000UF 25V	06651300
C3	CAP ELECT 10UF 50V	06644500
C11 C12	CAP MPF 1UF 5% 63VDC	06433700
C14 C21 C22 C26	CAP MONO .1UF 50V 20% Z5U	06130500

C15 C16 C28	CAP MPF 0.22UF 5% 63VDC	06432900
C27	CAP ELECT 1UF 50V	06651000
C29	CAP ELECT 22UF 100V	06650600
C30 C31	CAP ELECT 3300UF 35V	06650900
D1 D2 D3 D4 D5 D6 D7 D9 D10 D13 D14	DIODE SILICON	07004700
D15 D16 D17 D18 D19 D21 D22 D23 D24	DIODE SILICON	07004700
D27	DIODE ZENER 6.2V 5% 500MW	07008500
D28 D29	DIODE SILICON	07004700
D30 D31 D32	DIODE RECTIFIER	07013100
J1 J2	CONN 11 POS MALE	11727900
J8	CONN 3 POS MALE MTS100 NORMAL	11721400
J9	CONN MALE 7 PIN	11721700
J10	CONN 4 PIN	11721500
J12 J15 J16	BLADE FASTON W/FEET	11770800
K1	RELAY 48VDC	08704900
Q1 Q2 Q3 Q4 Q14 Q15 Q16 Q17 Q20	TRANSISTOR NPN	13222300
Q8 Q9 Q24 Q25	TRANSISTOR NPN	13225400
Q18	TRANSISTOR PNP	13222400
Q19	TRANSISTOR P CHAN JUNCTION FET	13222600
Q23	TRIAC DRIVER OPTOCOUPLER 600V	13102200
R1 R2	POT TRIM 100K OHM 20%	13438300
R3 R16	RES MF 4.75K 1% 1/4W	14409700
R4 R13 R15 R42	RES MF 2.21K 1% 1/4W	14429800
R5 R14 R55 R57	RES MF 22.1K 1% 1/4W	14418700
R6 R17 R61 R62	RES MF 33.2K 1% 1/4W	14401500
R7 R11 R23 R37	RES MF 200K 1% 1/4W	14411700
R8 R32	RES MF 10M 1% 1/4W	14426400
R9 R33	RES MF 18.2K 1% 1/4W	14418100
R10 R34 R56	RES MF 100 OHM 1% 1/4W	14419600
R12 R41 R64	RES MF 2.74M 1/4W	14427100
R30 R31 R36 R40 R70	RES MF 150K 1% 1/4W	14441900
R35 R39	RES MF 8.25 OHM 1/4W	14417100
R52 R53	RES MF 187K 1% 1/4W	14440600
R54 R59	RES MF 1M 1/4W	14426900
R58 R67	RES MF 681 OHM 1% 1/4W	14419500
R60	RES MF 1.1K 1% 1/4W	14409100
R63 R65 R66	RES MF 12.1K 1% 1/4W	14415400
R68	RES WW 1.5K 10% 5W	13907900
R69	RES WW 2.7 OHM 10% 2W	13917300
R71 R72	RES MF 475K 1% 1/4W	14436400
T1 T2	TRANSFORMER CURRENT	15921500
U2 U3 U4	IC OPERATIONAL AMPLIFIER	13318900
U5	IC NAND SCHMIT 2-IN X 4	13319200
U6	IC REGULATOR 12V	13315600
U7	IC REGULATOR -12V	13315500
U21	IC REGULATOR +5 VOLT	13309300
7 049799 INDICATOR		
D1 D2	LED AMBER	05813300
DS1	LED RED HIGH EFFICIENCY	05814800
DS2 DS3 DS4	LED GRN 5MM HI-INTENSITY	05816500
J1	CONN 11 POS MALE	11727900
J2 J5	CONN 4 PIN	11721500
J3 J4	HEADER 2 PIN LATCHING	11776600
R1	RES MF 365 OHM 1% 1/4W	14407100
R2	RES MF 619 1/4W 1%	14448500
8 049809 METERLED		
DS1 DS2 DS5 DS6	LED BLU 5MM HI-INTENSITY	05816600
DS3 DS4 DS7 DS8	LED GRN 5MM HI-INTENSITY	05816500
J1	CONN 4 PIN RIGHT ANGLE	11724000
R1 R3 R5 R7	RES MF 221 OHM 1% 1/4W	14417200
R2 R4 R6 R8	POT TRIM 500 OHM 20% HORIZ ADJ	13441000

EXPLODED VIEW

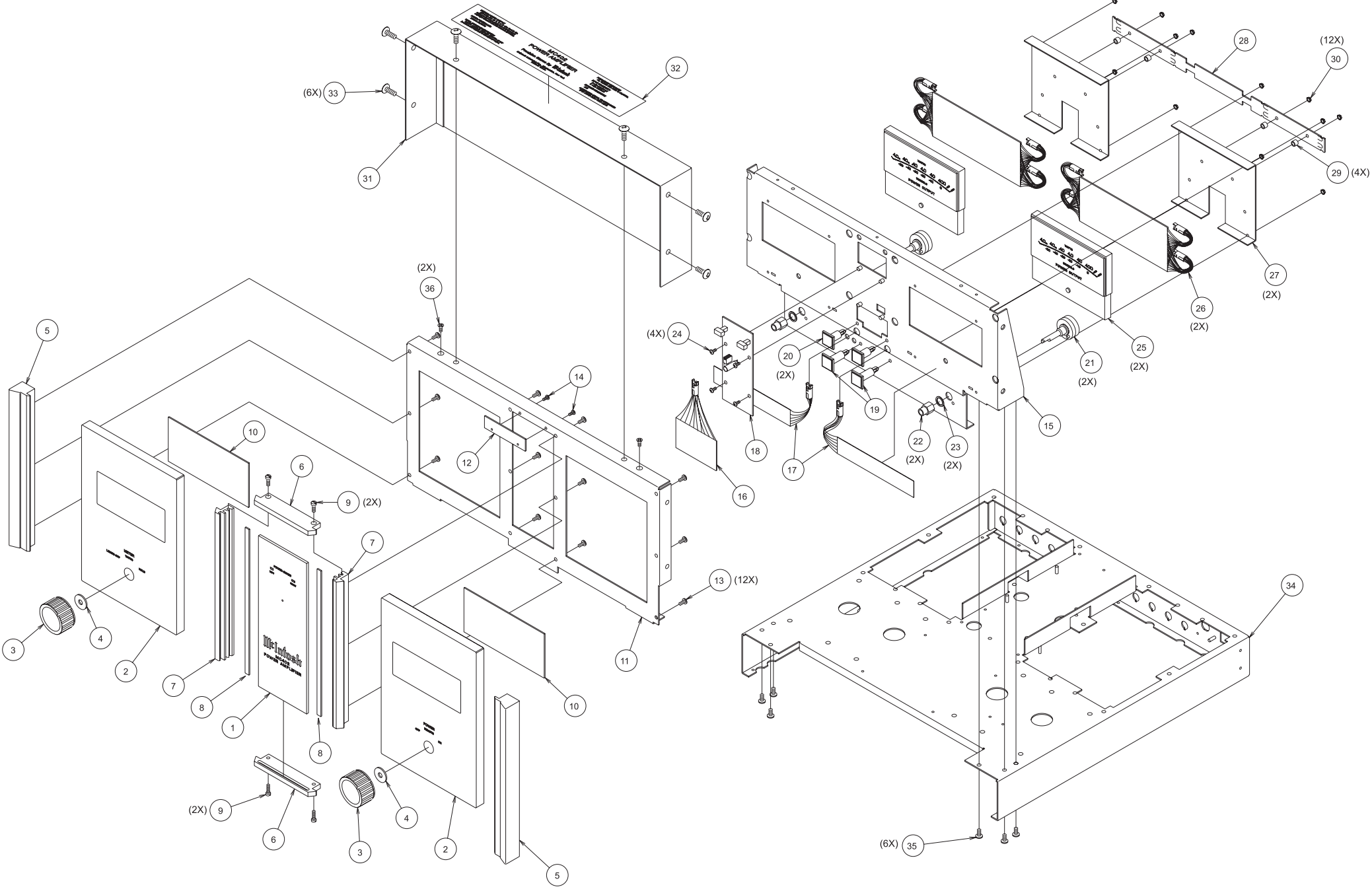

EXPLODED VIEW con't

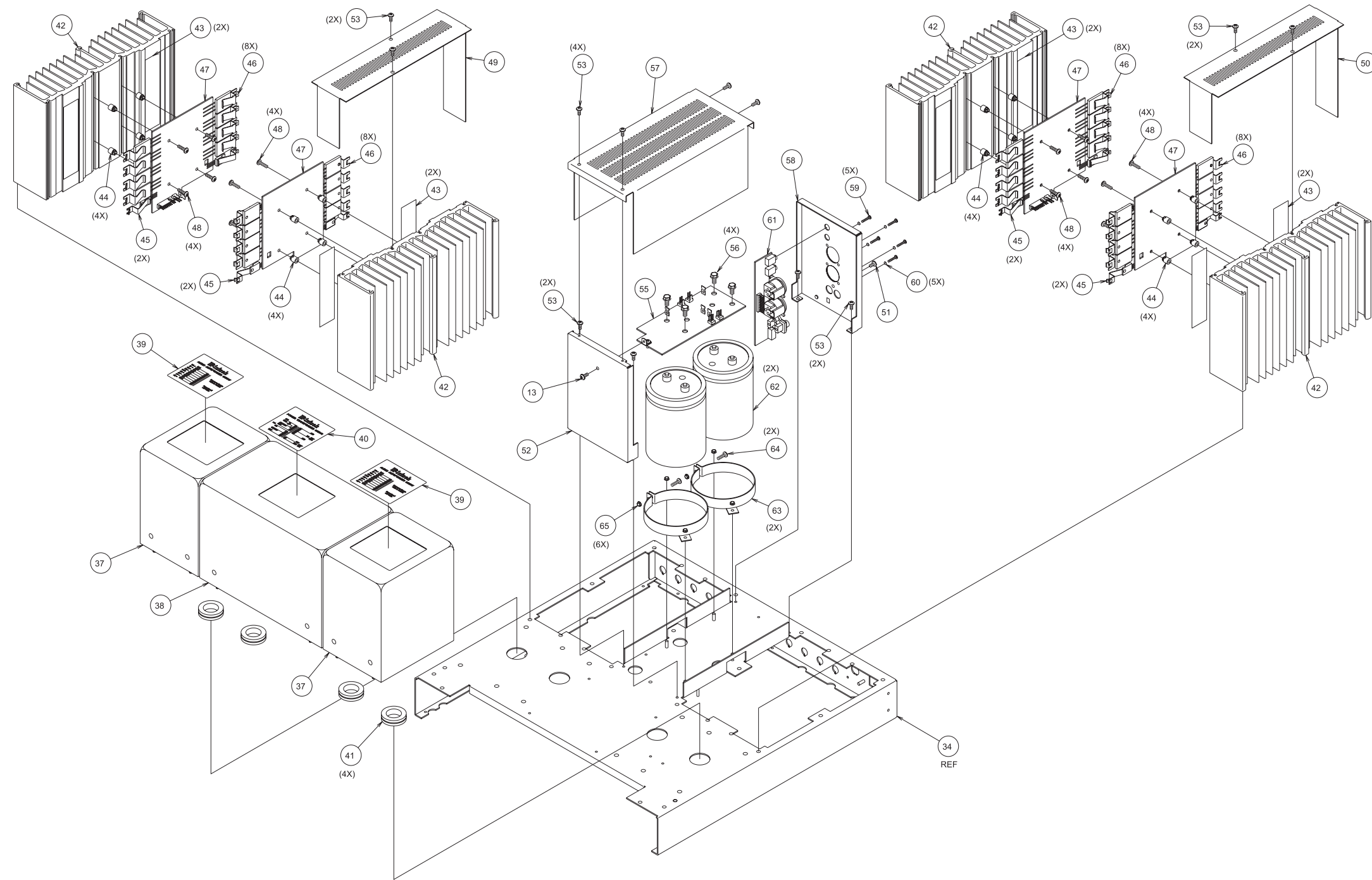

EXPLODED VIEW con't and PARTS LIST

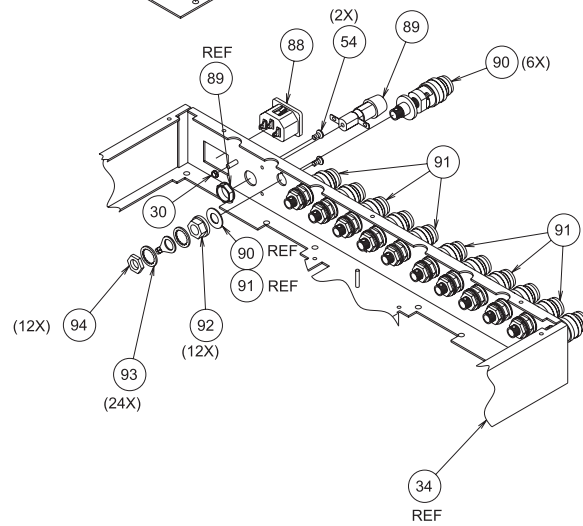
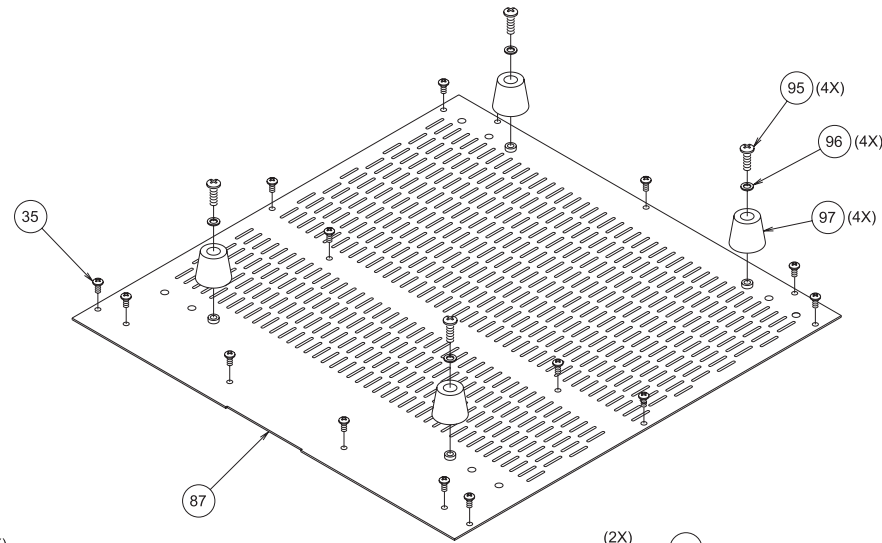
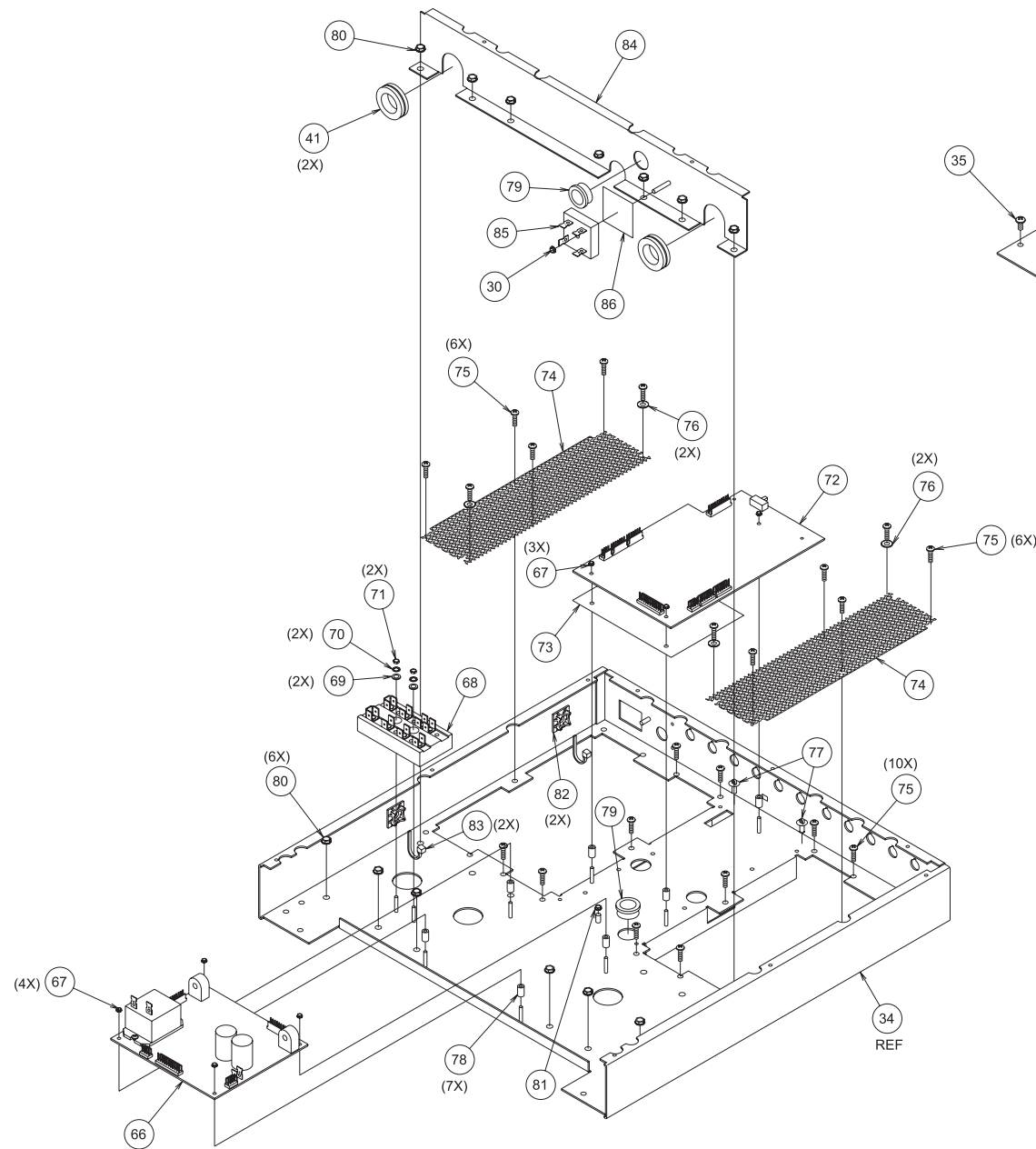

Ref No.	Part No.	Description
1	016485	CENTER GLASS PANEL
2	016487	GLASS PANEL W/HOLE
3	049321	ASSY KNOB
4	104017	WASHER FELT BLK 3/4 X 1/4 X 1/16
5	018709	END CAP
6	018710	TOP/BOTTOM END CAP
7	018711	CENTER EXTRUSION
8	094024	TAPE FOAM 1/16 X 1/4
9	100342	SCREW FILLISTER HEAD
10	092426	FILTER COLOR METER
11	005283	REAR PANEL PLATE
12	005312	PLATE GAP

13	100276	SCREW MACH SEMS 6-32 X 5/16 PH PN
14	101074	SCREW TAPPING 4-40 X 1/4
15	005289	SUBPANEL
16	017913	LOGO BACKLIGHT
17	017901	LOGO PUSHBUTTON BACKLIGHT
18	049799	ASSY INDICATOR PCB
19	017919	LOCKING PCB SUPPORT 7/8"
20	017918	LOCKING PCB SUPPORT 5/8"
21	146243	SWITCH POWER
22	021159	BUSHING SWITCH
23	104014	WASHER INT STAR 3/8 X .507 X .002
24	100121	SCREW MACH 4-40 X 1/4 PH PN BLK
25	124085	METER
26	017881	BACKLIGHT METER
27	005299	METER PLATE
28	049809	ASSY METER LED PCB
29	021053	SPACER #6 X 3/16 STEEL
30	102003	NUT MACH 6-32 W/LOCK
31	005291	DUST COVER
32	126917	DECAL TOP COVER
33	100200	SCREW MACH 10-32 X 1/2 PH TRUSS HD
34	005290	CHASSIS
35	101078	SCREW TAP 8-32 X 5/16 PH PN BLK

36	101172	SCREW TC 6-32 X 1/4 PH FL U/C
37	049817	POTTED TRANSFORMER OUTPUT
38	049818	POTTED TRANSFORMER POWER
39	126895	DECAL OUTPUT TRANSFORMER
40	126896	DECAL POWER TRANSFORMER
41	078025	GROMMET 3/4"
42	018614	HEATSINK
43	084156	ISOSTRATE POWER SUPPLY
44	112087	SPACER PCB 1/4"
45	114118	CLIP TRANSISTOR 218
46	114119	CLIP TRANSISTOR 214
47	049826	ASSY HEATSINK PCB
48	101059	SCREW SM 6 X 5/8 PH PN TYPE A
49	004928	HEATSINK COVER LEFT
50	004958	HEATSINK COVER RIGHT
51	101109	ST 6-32 X 5/16"
52	004919	SUBREAR PANEL
53	101054	SCREW TAPTITE 6-32 X 1/4 PH PN BLK
54	100250	SCREW MACH SEMS 8-32 X 1/4
55	049216	ASSY CAPACITOR PCB
56	100188	SCREW, MACH SEMS 10-32 X 3/8
57	004922	COVER CAPACITOR
58	005288	REAR PANEL
59	101114	SCREW SM 4-24 X 1/2 PH PN TYPE A
60	104095	WASHER INT STAR #4
61	049222	ASSY INPUT PCB
62	066480	CAP ELECT 5400uF 75VDC
63	003855	CLAMP CAPACITOR
64	100118	SCREW MACH 6-32 X 1/2 PH PN
65	102045	NUT KEP 6-32 SPECIAL
66	049798	ASSY METER PCB
67	102001	NUT KEP 4-40 CADMIUM PLATE
68	074091	TERMINAL BLOCK AC
69	104001	WASHER FLAT STEEL 4 X 9/32 X .025
70	104004	WASHER LOCK 5 X .255 INT STAR
71	102022	NUT MACH 4-40 X 3/16 X 1/16
72	049219	ASSY DRIVER PCB
73	017770	SHIELD PCB
74	004954	HEATSINK VENT
75	101176	SCREW TC6-32 X 1/2 PH PN TYPE F
76	104005	WASHER FLAT STEEL 6 X 3/8 X .032
77	017760	PLASTIC CUPPED PCB SUPPORT 3/8"
78	112038	SPACER STEEL 4 X 3/8 L NCKL PLT
79	078034	GROMMET
80	102006	NUT MACH 10-32 W/LOCK
81	102005	NUT MACH 8-32 W/LOCK
82	017518	HOLDER CABLE TIE
83	094255	CABLE TIE PANDUIT PLT1M-M
84	004930	BRACKET CHASSIS SUPPORT
85	070139	DIODE BRIDGE RECTIFIER
86	084135	PAD THERMAL
87	005301	BOTTOM COVER
88	117487	RECEPTACLE AC LINE
89	178122	HOLDER FUSE SOCKET UL/CSA
90	117740	POST BINDING RED
91	117741	POST BINDING BLK
92	102052	NUT GOLD SUPPLIED W/117758
93	104162	WASHER LOCK INT TOOTH
94	102015	NUT HEX M9 X .75 GOLD PLATED
95	100159	SCREW MACH 10-32 X 3/4 PH PN
96	104080	WASHER FLAT #10 CLEAR ZINC
97	017218	FOOT PLASTIC BLACK

REPACKING INSTRUCTIONS

In the event it is necessary to repack the unit for shipment, the unit must be packed exactly as shown below.

IMPORTANT - For ease of shipment, attach the four feet to the bottom of the unit. Four, 1/4 - 20 x 2-1/4 bolts with washers must be used to fasten the unit securely to the wood skid. Failure to do this will result in shipping damage.

If a shipping carton or any of the interior parts is needed, please call or write the Customer Service Department of McIntosh Laboratory. Order parts from the accompanying list by part number.

Use the original shipping carton and interior parts only if they are in good serviceable condition.

Qty.	Part No.	Description
1	034051	Shipping carton bottom
2	034186	Foam pad (front and rear)
2	034187	Foam Pad (side)
2	034054	Foam pad (top and bottom)
1	034052	Shipping carton (top)
1	034137	Inner carton (bottom)
1	034226	Shipping skid
1	034188	Foam pad (inner carton)
1	034136	Inner carton (top)
4	101212	1/4 - 20 x 2-1/4 cap screw
4	104058	Flat washer

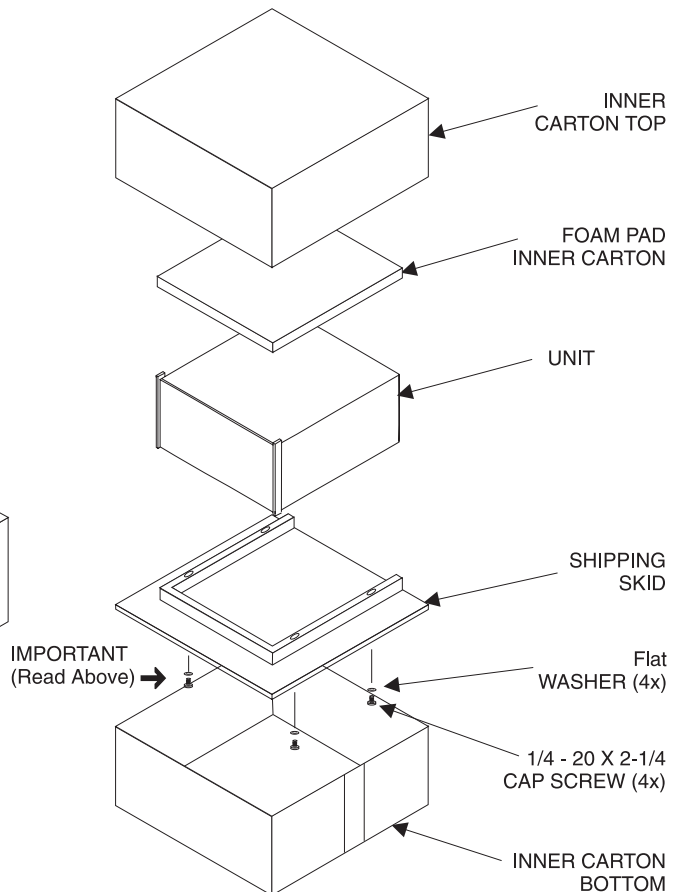
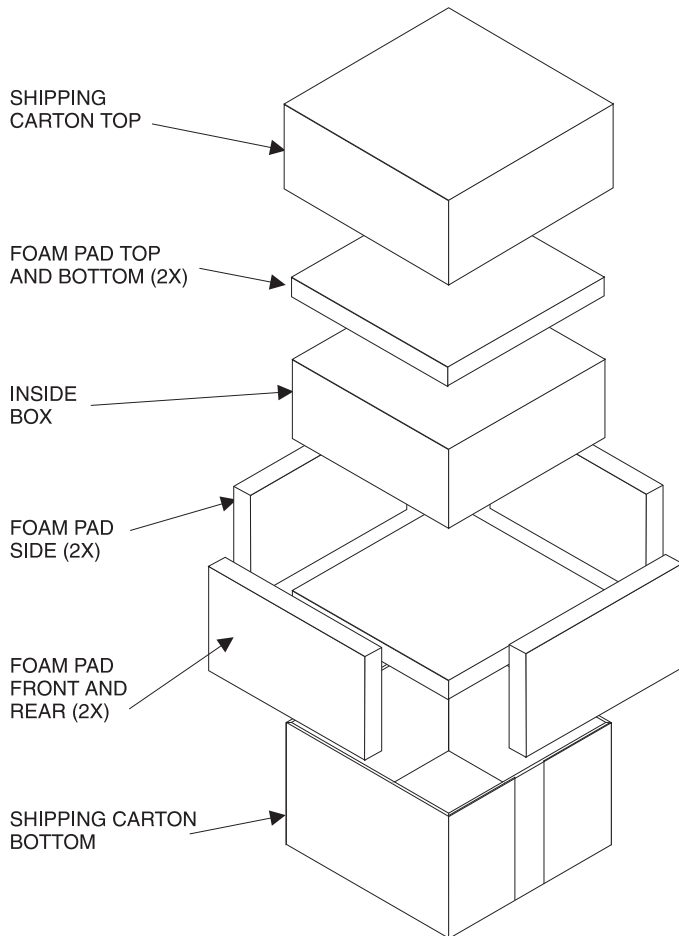

MC402

POWER AMPLIFIER

SERVICE MANUAL



The continuous improvement of its products is the policy of McIntosh Laboratory Incorporated, who reserve the right to improve design without notice. Because of the constant upgrading of McIntosh products' circuitry and components, the Company cannot insure, and does not warrant, the accuracy of the within schematic material, which is intended for information only.